

Date issued: December 16, 2005

Subject: Treatment of Ice Maker Volume in Accordance with ANSI/AHAM HRF-1-2004.

Question:

Can the volumes listed in 1) through 5) below be included in the total refrigerated volume?

Answer:

1) Ice Maker: the whole ice maker volume including the ice maker operating part.

Staff response: Yes, in accordance with 4.2.1.1(a) for the volume of the ice maker.

2) Water filter: the whole filter volume except with filter holder.

Staff response: Yes, for the water filter. However, the volume of the filter holder may also be included in the total refrigerated volume, i. e. it may be regarded as not existing. There are two provisions in HRF-1 which support this interpretation.

The first paragraph of 4.2.1.1(a) states that (The refrigerated volume is to include) "Volume occupied by special features, such as baskets, crispers, meat pans, chiller trays, icemakers (including storage bins for automatic icemakers) and water coolers." The water filter and its holder are to be regarded as a "special feature" in this category.

The first sentence of the second paragraph of 4.2.1.1(a) states that (The refrigerated volume is to include) "In the case of through-the-door ice and/or liquid dispensers, the volume occupied by all parts of the apparatus that are components of its design." The water filter and its holder are considered part of the design of the ice maker.

Additionally, concerning the water filter only, 4.2.1.1(c) allows the inclusion of "Volume occupied by features, such as light shields, trims, and aesthetic items, which are removable without the use of tools." Since the filter is designed to be removed by hand, it comes into this category.

None of the above applies if the water filter is located outside of the refrigerated compartment.

3) Dispenser (Cup Place): the whole dispenser volume.

Staff response: Not the whole volume marked on the photographs. In the photographs provided, the edge of the fountain aperture has been marked as the limit of the measured volume. This is incorrect. The volume of the fountain cavity forward of the plane of the door front surface may not be included. Please refer to the third sentence of the second paragraph of 4.2.1.1(a), "Include that portion of the volume of the fountain cavity extending to the door front surface (between the inner door liner and outer door face) even though that volume is forward of the door liner."

Furthermore, from review of fig. 4-18 it is not permissible to include the volume of any sump below the level of the bottom of the aperture between the inner door liner and the door front surface.

Photograph provided:



Figure 4-18 from AHAM HRF-1: 2004

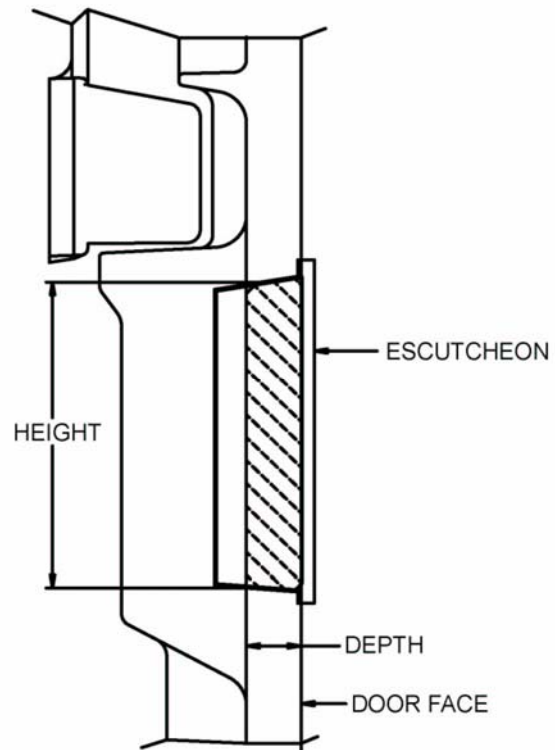

Side-view of fountain

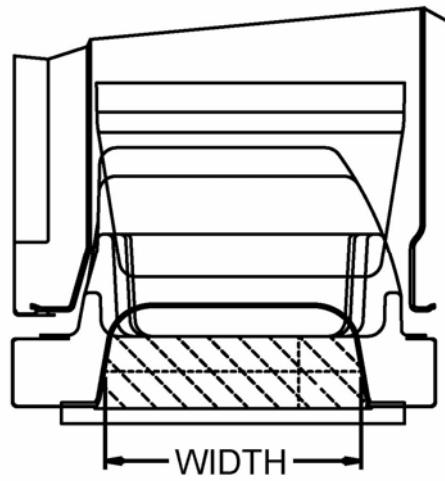

Top view of fountain

Figure 4-18 — Measurement of Icemaker Volume

- 4) Insulation Hump: the whole Hump volume including projecting hump out from inner case.

Staff response: Yes. However the volume calculation specified in the second sentence of the second paragraph of 4.2.1.1(a) is “...average height x average width x average depth, or the actual volume as indicated by fig. 4-18.” However, it is not clear to us that the numbers used in your calculation are consistent with the numbers marked on the photographs.

Notwithstanding the above, in practice it is not necessary to measure the hump volume since all of its volume can be included in the measured volume of the freezer. Therefore it is as though the hump can be regarded as not existing.

This interpretation applies to the insulating humps of through-the-door ice and/or liquid dispensers only.

- 5) Geared Motor Box: the whole volume of Geared Motor Box.

Correct. Once again, as in item 2, this is a “Component of its design.”